



APPLIED TEST  
SYSTEMS, INC.

*Product  
Bulletin*

THE MARK OF RELIABILITY

# Series 1100

## Universal Testing Machines

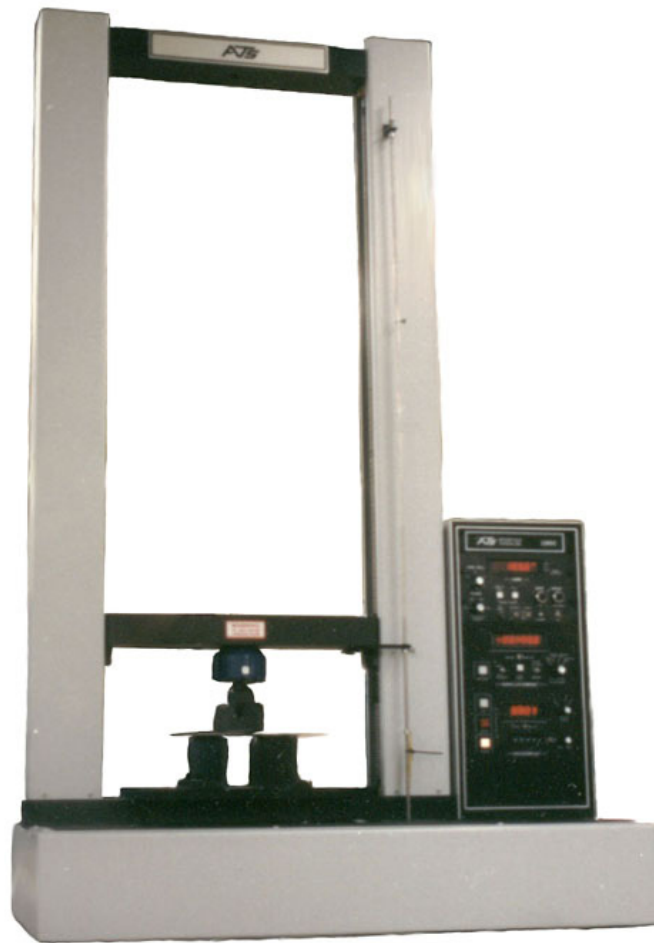

Low-Cost, Compact Capability

---

# Features

The ATS Model 1101 Universal Testing Machine is an economical benchtop system which performs tension, compression, shear, and flexure testing with twin-screw accuracy in capacities up to 1,000 lbs.

Testing is performed below the moving crosshead, maximizing operator convenience and ease of use. Additionally, the compact design of this system is ideal for facilities with space limitations.

The 14 in. (356mm) nominal clearance between columns and 42 in. (1066mm) standard crosshead travel provide an extra-large testing area to easily accommodate various sizes of chambers, fixtures, and samples.

As with all models of ATS equipment, a wide variety of accessories is available to provide added capability and flexibility, including data acquisition and recording systems, furnaces, heating and cooling chambers, fixtures, grips, and more.

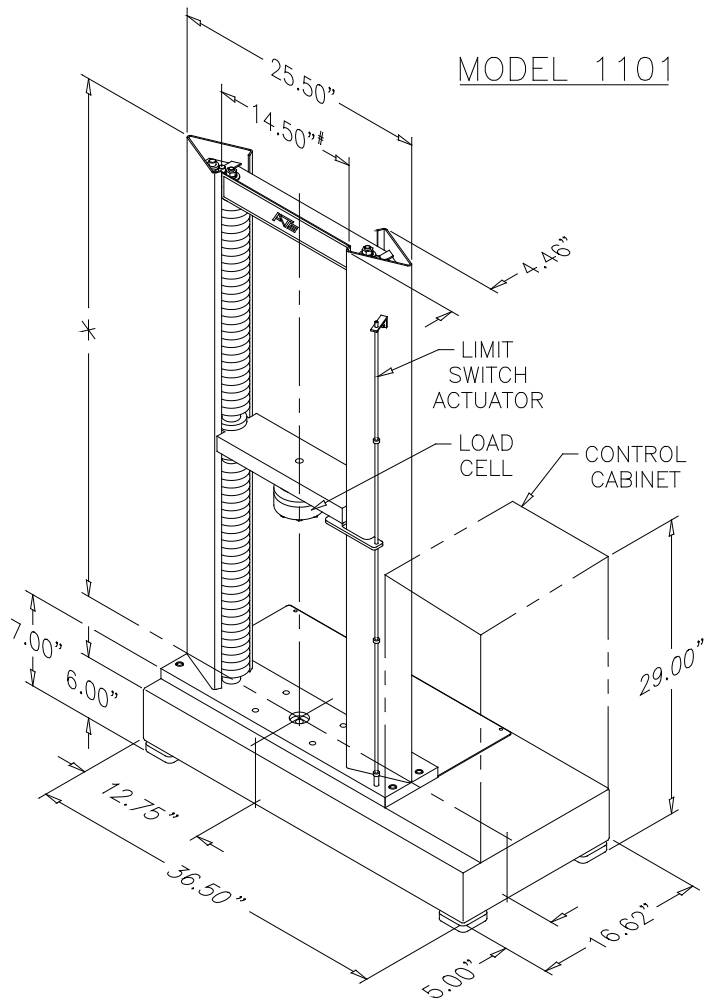

\* MACHINE HEIGHT VARIES BASED UPON REQUIRED CROSSHEAD TRAVEL / VERTICAL CLEARANCE.

# DISTANCE SHOWN IS BETWEEN UTM COLUMN SHROUDS. SEE SPECIFICATIONS SHEET FOR USABLE HORIZONTAL CLEARANCE.

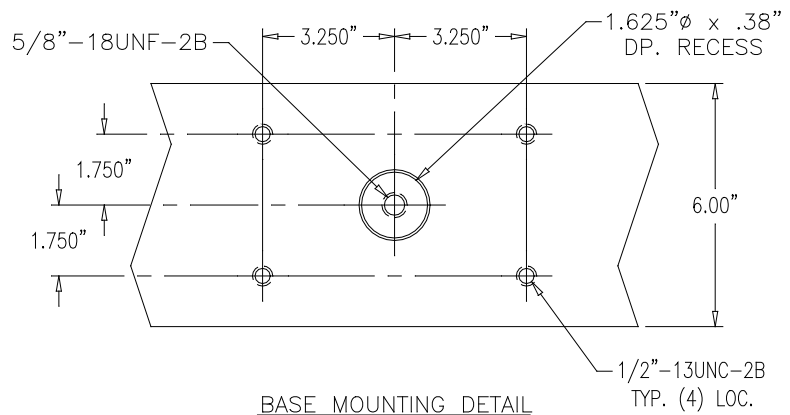

# Features

The ATS Model 1105 Universal Testing Machine is a basic system designed for efficient and straightforward operation, performing tension, compression, shear, and flexure tests in capacities up to 5,000 lbs.

Metals, plastics, elastomers, composites, and many other materials can be tested. The simplicity, economy, and compact design of this system make it ideal for small laboratories and universities with limited space and limited budgets.

A full 42 in. (1066mm) of standard crosshead travel and 20 in. (508mm) of nominal horizontal clearance provide a versatile testing area for accommodation of various sizes of chambers, fixtures, and samples. Twin-screw guided crossheads provide accurate test results. Controls are housed in a separate, remote console for maximum versatility.

Basic capabilities are easily expanded with the addition of available options and accessories, including data acquisition and recording systems, furnaces, heating and cooling chambers, fixtures, grips, and more.

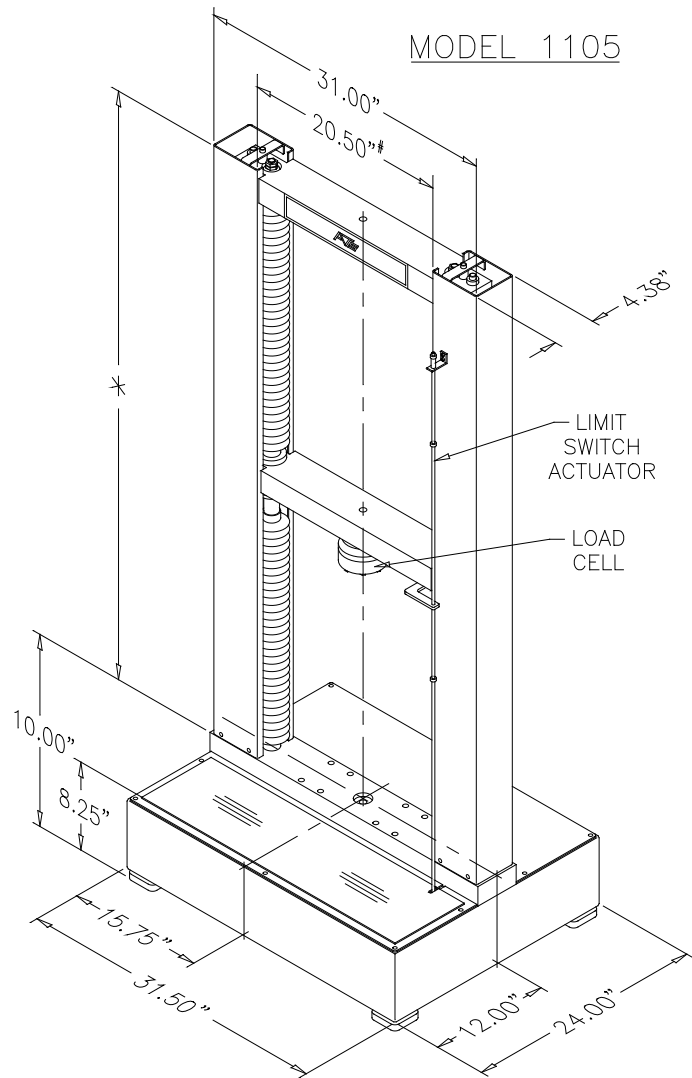

\* MACHINE HEIGHT VARIES BASED UPON REQUIRED CROSSHEAD TRAVEL / VERTICAL CLEARANCE.

# DISTANCE SHOWN IS BETWEEN UTM COLUMN SHROUDS. SEE SPECIFICATIONS SHEET FOR USABLE HORIZONTAL CLEARANCE.

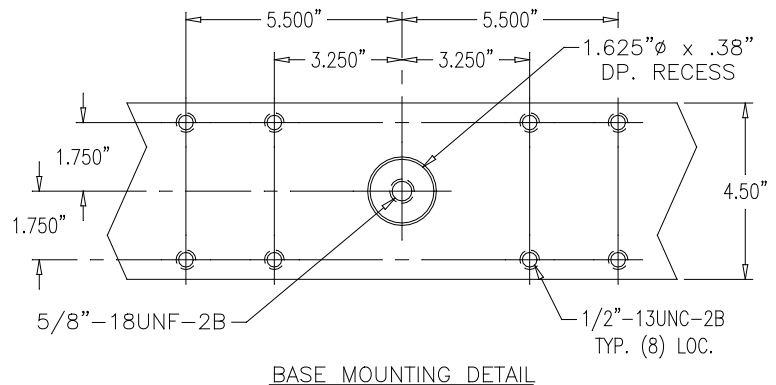

# Features

The Model 1105C Universal Testing Machine has been designed for those with tight budgets and minimum lab space who must meet tension and compression testing requirements in up to 5,000 lb. capacities.

This compact, bench-top test frame with attached space-saving control console fits easily into snug spaces. The simple, accurate controls common to all Series 1100 systems are user-friendly in a wide range of testing applications, from quality control to high-end research.

A full 42 in. (1066mm) of standard crosshead travel with 20 in. (508mm) of nominal horizontal width provide a large testing area for easy accommodation of various sizes of temperature-controlled environmental chambers, fixtures, and samples.

If testing requirements are upgraded in the future, basic capabilities are easily expanded with the addition of such ATS accessories as data acquisition and recording systems, furnaces, heating and cooling chambers, fixtures, grips, and more.

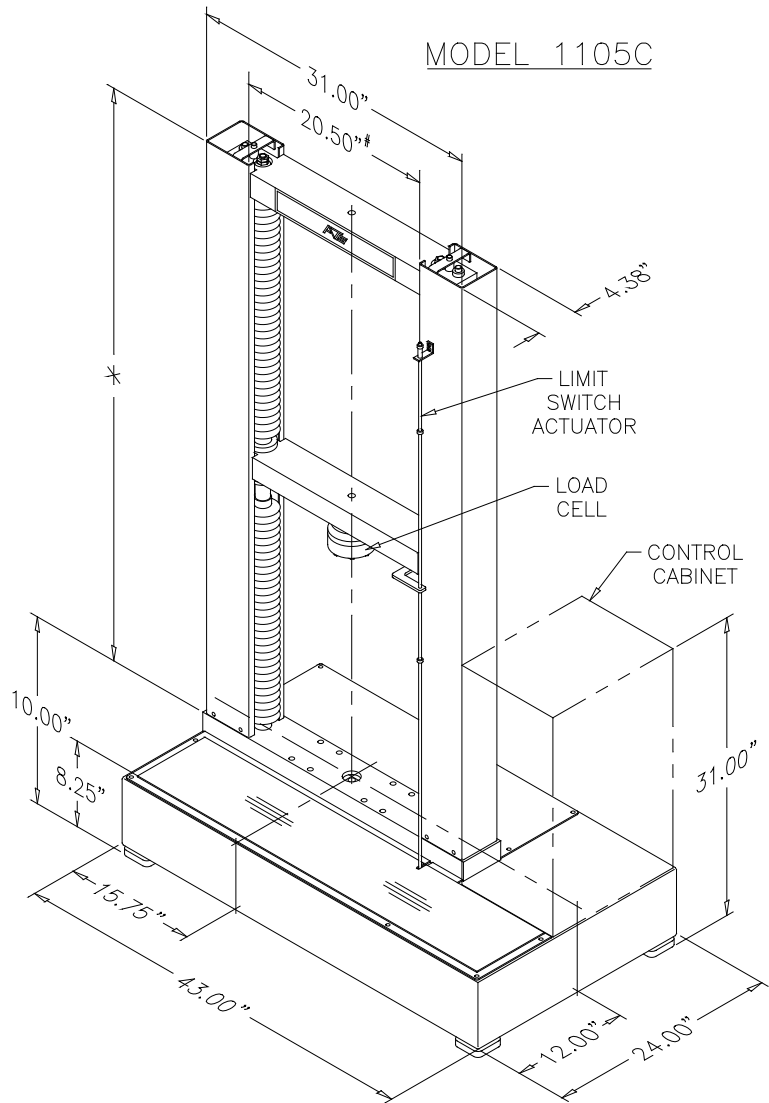

\* MACHINE HEIGHT VARIES BASED UPON REQUIRED CROSSHEAD TRAVEL / VERTICAL CLEARANCE.

# DISTANCE SHOWN IS BETWEEN UTM COLUMN SHROUDS. SEE SPECIFICATIONS SHEET FOR USABLE HORIZONTAL CLEARANCE.

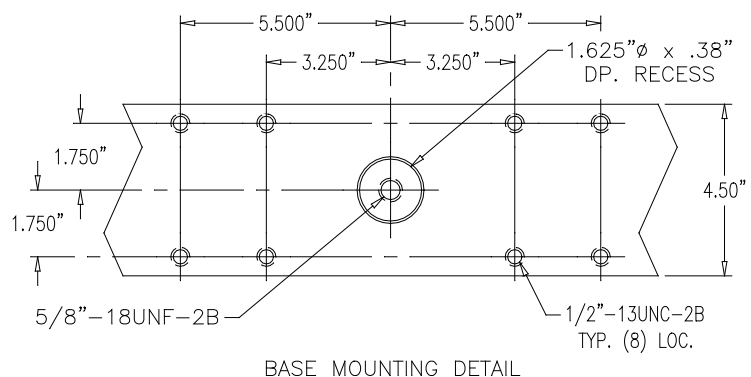

# Features

Models 1110 and 1120 Universal Testing Machines are rugged floor-standing systems with controls mounted in a separate, remote cabinet.

Tension, compression, shear, and flexure tests on a variety of materials can be performed in capacities up to 10,000 and 20,000 lbs., respectively.

Testing is performed below the moving crosshead for maximum operator convenience. The ATS two-column design provides stability, making these machines ideal for high-capacity materials testing of various types of specimens.

A versatile testing area, with 24 in. (610mm) of nominal horizontal clearance and a full 42 in. (1066mm) of standard crosshead travel, easily accommodates a wide variety of environmental chambers, fixtures, and samples.

As always, a wide variety of accessories is available to provide added capability and flexibility. These include data acquisition and recording systems, furnaces, heating and cooling chambers, fixtures, grips, and more.

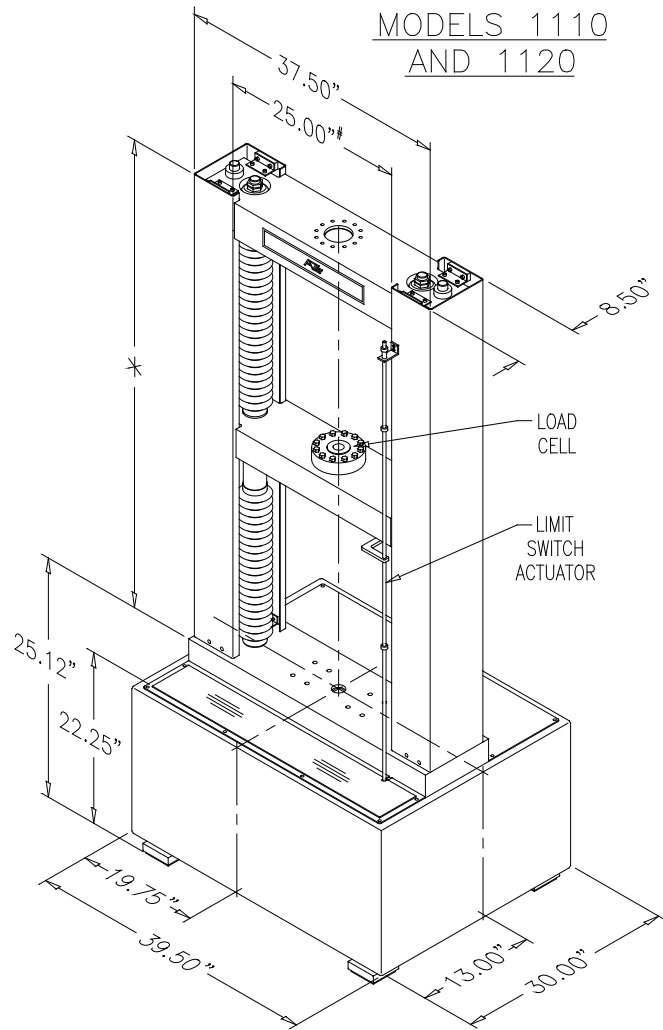

\* MACHINE HEIGHT VARIES BASED UPON REQUIRED CROSSHEAD TRAVEL / VERTICAL CLEARANCE.

# DISTANCE SHOWN IS BETWEEN UTM COLUMN SHROUDS. SEE SPECIFICATIONS SHEET FOR USABLE HORIZONTAL CLEARANCE.

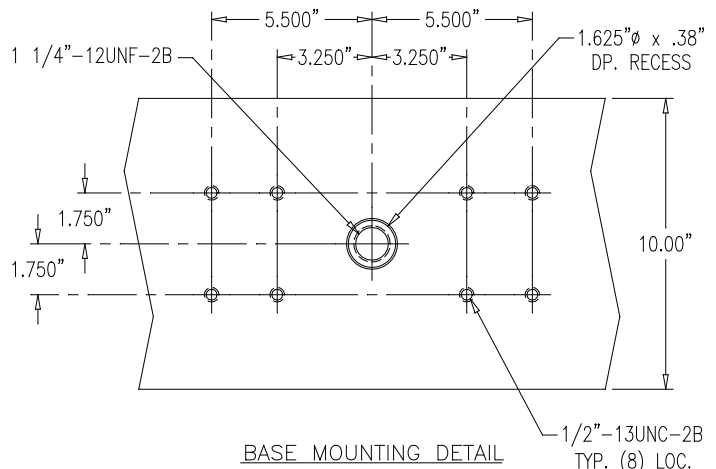



# Specifications

<b>LOAD FRAME</b>	<b>1101</b>	<b>1105/1105C</b>	<b>1110/1110C</b>	<b>1120/1120C</b>
Capacity	1,000 lbf. (4.4kN)	5,000 lbf. (22.2kN)	10,000 lbf. (44.4kN)	20,000 lbf. (88.9kN)
Horizontal Clearance*	14 in. (356mm)	20 in. (508mm)	24 in. (610mm)	24 in. (610mm)
Type	Bench top	Bench top	Floor model	Floor model
Testing Area	Tension and compression below moving crosshead			
Crosshead Guidance	Twin-screw drive with independent chrome-plated guide rods			
Vertical Clearance	42 in. (1066mm) STANDARD, excluding grips or fixtures <sup>#</sup>			
Crosshead Travel	42 in. (1066mm) STANDARD <sup>#</sup>			
Limit Switches	Manually adjustable			
System Controls	Models 1101/1105C/1110C/1120C feature integrated controls Models 1105/1110/1120 feature a remote control cabinet			

## **CROSSHEAD CONTROLS**

Speed Ranges (English Units) <sup>o</sup>	Model 1101: 0.200-20.00 or 0.002 to 20.00 in./min Models 1105/1105C: 0.020-20.00 or 0.002-20.00 in./min Models 1110/1110C/1120/1120C: 0.002-20.00 in./min
Speed Ranges (Metric Units) <sup>o</sup>	Model 1101: 5.0-500 or 0.1 to 500 mm/min Models 1105/1105C: 0.5-500 or 0.1-500 mm/min Models 1110/1110C/1120/1120C: 0.1-500 mm/min
Crosshead Speed Selection	0.1% increments of speed range
Speed Accuracy	±1% averaged
Digital Speed Display	English or metric units

## **LOAD MEASURING**

Load Weighing Accuracy	±0.5% of indicated load, ±0.1% of range in use
Ranges	10%, 20%, 50%, 100% of load cell in use
Automatic Overload Protection	STANDARD
Peak Load Recall	STANDARD
Digital Display	STANDARD - selectable English or metric units
Load Cells Available	Under 1 lb. through 20,000 lbs. Up to five load cells can be used
Automatic Break Detect	STANDARD

## **REQUIREMENTS**

Power Requirements	120 or 240 VAC, 1 Phase, 50/60 Hz
--------------------	-----------------------------------

## **DISPLACEMENT MEASURING SYSTEM AND ZERO-RETURN**

High Precision	Optical incremental encoder
Range	Full crosshead travel
Output Range to Recorder	0.2 in., 2 in., 10 in., or 20 in. at 10V full scale
Display	Digital
Resolution	0.0001 in. (0.001mm)
Zero Return	Push-button actuated return to zero position

\* Value shown is maximum horizontal clearance without optional screw covers.

# Extended crosshead travel and vertical clearance are available.

<sup>o</sup> Also available is a "slow strain" drive system for testing at significantly reduced speeds.

Consult an ATS sales engineer for further details regarding this option.

*Specifications subject to change without notice*

# Controls

Series 1100 Universal Testing Machines have been designed with a simple yet accurate interface, making them useful for everything from quality control applications to high-end research. A diagram and detailed descriptions of these controls can be found on this and the following page.

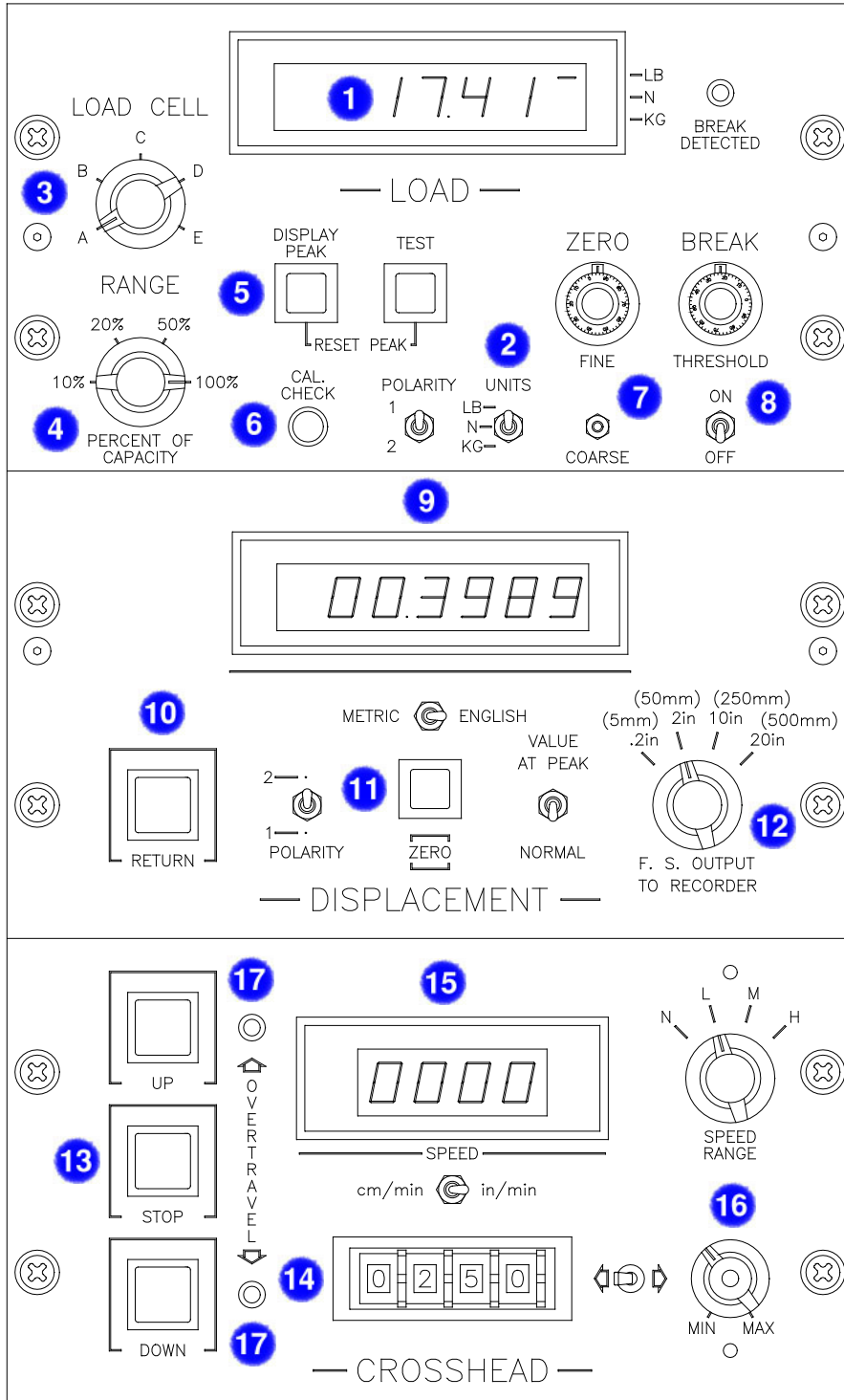

SERIES 1100



## LOAD

- 1 Large digital readout display:** The precise load being applied to the specimen is clearly visible throughout the test. As an added safety feature, an **electronic overload protection system** automatically stops crosshead travel when 105% of the load range has been reached.
- 2 Choice of measuring units:** Choose from pounds, Newtons, or kilograms at the flip of a switch. An illuminated LED at the far right of the display indicates which measuring unit is currently being used.
- 3 Multiple load cell capacity:** Testing is not restricted to one load cell. Up to five different cells can be used, and auxiliary load cells can be added at any time.
- 4 Selectable load cell range:** For increased accuracy, a range of 10%, 20%, 50%, or 100% of the capacity of the current load cell can be selected. Each range is independently calibrated and provides a full 0-10 VDC output to the recorder or data system.
- 5 Peak load recall:** The maximum load achieved is automatically retained in memory, eliminating the need for monitoring the system during testing.
- 6 Calibration verification:** A microprocessor-based signal conditioner is designed to maintain calibration, so daily calibration of the machine is not required. Calibration can be verified at any time by pressing the calibration check button.
- 7 Fine and coarse zero adjustments:** The weights of pull rods, grips, and specimens (tare value) can be excluded from the test (up to 50% of the load cell capacity).
- 8 Automatic break detection system:** Featuring adjustable sensitivity and an on/off control. When switched on, the break detector constantly monitors the current load and compares it to the peak load to determine whether a break has occurred.

## DISPLACEMENT

- 9 Digital crosshead travel readout:** A high-resolution optical incremental encoder displays crosshead travel with resolution to 0.0001 in. Displacement can be displayed in inches or millimeters. When extensometers are not used, the output from the displacement measuring system can provide the signal for the x-axis on an x-y recorder.
- 10 Rapid crosshead return:** The crosshead returns to zero or starting position at the push of a button, reducing setup time between tests.
- 11 Zero reset button:** Reset the zero or starting position to the current position of the crosshead by pushing this button.
- 12 Output range selector:** Provides units of 0.2 in., 2.0 in., 10 in., and 20 in. at 10V full scale.

## CROSSHEAD

- 13 Manual crosshead controls:** A set of “up-down-stop” buttons provide a simple interface for operating the machine.
- 14 Precise speed selection:** Set the desired speed of the crosshead using this digital thumbwheel switch.
- 15 Digital crosshead speed display:** Shows the actual speed of the crosshead, selectable in either inches or millimeters.
- 16 Variable speed control:** Allows for test setup positioning without disturbing the preset test speed.
- 17 Crosshead travel limit indicators:** These LEDs illuminate when limits have been reached in either direction. Mechanical user-adjustable limits are provided on the front of the machine to protect grips and fixtures from damage due to overtravel.

*Note: Remote console machines with free-standing cabinets feature the same controls in a slightly modified layout.*

# Custom Equipment

Applied Test Systems, Inc. has an excellent reputation in the materials testing industry as a leading supplier of custom equipment. We welcome all inquiries into any system or setup you may have in mind. Below are just a few examples of how we can put our decades of experience to work for you.



*Series 1120C UTM integrated with a 60" span bend test fixture. Used for static testing of timbers per ASTM designation D198-84.*



*Series 1105C UTM with extended crosshead travel and vertical clearance. Equipped with special platens for testing of large-diameter plastic pipe.*



**Calibration Laboratory**  
Certificate No. 2132.01  
*Inclusion of this logo does not imply certification/approval of the products calibrated.*

**ATS APPLIED TEST SYSTEMS, INC.**  
154 East Brook Lane  
Butler, PA 16002

Phone: (724) 283-1212  
Toll-Free: (800) 441-0215  
Fax: (724) 283-6570  
eMail: [sales@atspa.com](mailto:sales@atspa.com)  
<http://www.atspa.com>

