

Series 900

Universal Testing Machines



Precision Benchtop Testing

Features

ATS Models 905 and 910 Universal Testing Machines provide an affordable solution to precision testing where requirements demand high accuracy in capacities up to 5,000 and 10,000 lbs., respectively.

The compact benchtop design of these systems consumes a minimal amount of valuable laboratory space while performing tension, compression, shear, and flexure tests on a variety of materials.

A few of the outstanding features of these systems include a microprocessor-based load cell signal conditioner and precise speed control. An extra-large testing area easily accommodates various sizes of chambers, fixtures, and samples. Rigid-column construction with single-screw drive provides precise alignment during testing procedures. Columns are heat treated and hard-chrome plated for extended life and durability.

Additionally, a variety of accessories is available to provide extended capability and flexibility. These include furnaces, heating and cooling chambers, recorders, fixtures, grips, and more.

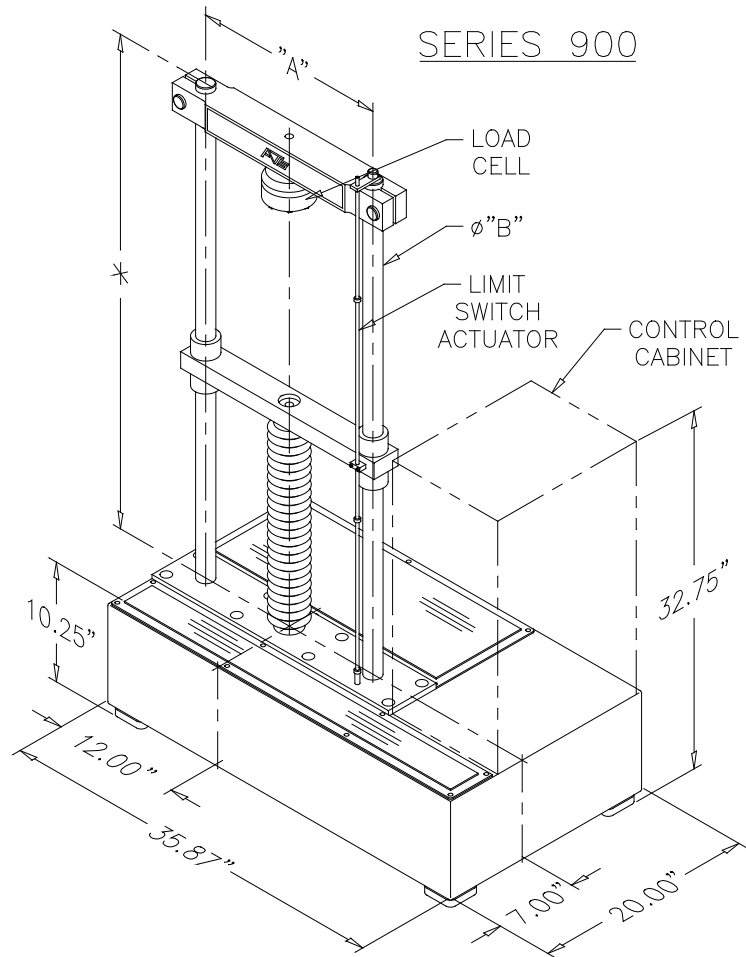

* MACHINE HEIGHT VARIES BASED UPON REQUIRED CROSSHEAD TRAVEL / VERTICAL CLEARANCE.

MODEL	"A"	"B"	"C"	"D"
905	17.50"	1.50"	2.50"	5/8"-18UNF-2B
910	18.00"	2.00"	3.00"	3/4"-16UNF-2B

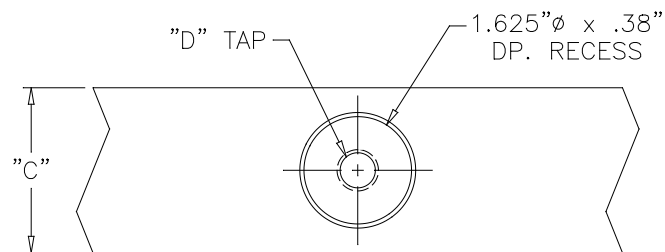

MOVING CROSSHEAD DETAIL

Specifications



LOAD FRAME

Capacity	Model 905: 5,000 lbf. (22.2kN) Model 910: 10,000 lbf. (44.4kN)
Type	Bench top, single screw
Testing Area	Tension and compression above moving crosshead
Horizontal Clearance	16 in. (406mm)
Vertical Clearance	36 in. (914mm) STANDARD, excluding grips or fixtures*
Crosshead Travel	24 in. (610mm) STANDARD*
Limit Switches	Manually adjustable
Crosshead Guidance	Independent chrome-plated guide rods
Upper Crosshead	Adjustable

CROSSHEAD CONTROLS

Speed Range	0.02-2.00 in./min (0.50-50mm/min) STANDARD 0.20-20.00 in./min (5.0-500mm/min) OPTIONAL
Crosshead Speed Selection	0.1% increments of speed range
Speed Accuracy	±1%
Digital Speed Display	English or metric units

LOAD MEASURING

Load Weighing Accuracy	±0.5% of indicated load ±0.1% of range in use
Ranges	10%, 20%, 50%, 100% of load cell in use
Automatic Overload Protection	STANDARD
Peak Load Recall	STANDARD
Digital Display	STANDARD - selectable English or metric units
Load Cells Available	Under 1 lb. Through 10,000 lbs. Up to five load cells can be used
Automatic Break Detect	STANDARD

REQUIREMENTS

Power Requirements	120 or 240 VAC, 1 Phase, 50/60 Hz
--------------------	-----------------------------------

DISPLACEMENT MEASURING SYSTEM AND ZERO-RETURN (Optional)

High Precision	Optical incremental encoder
Range	Full crosshead travel
Output Range to Recorder	0.2 in., 2 in., 10 in., or 20 in. at 10V full scale
Display	Digital
Resolution	0.0001 in. (0.001mm)
Zero Return	Push-button actuated return to zero position

ACCESSORIES

A wide variety of options is available for use with these systems, including chambers, extensometers, grips, recorders, etc.

* Extended crosshead travel and vertical clearance are available

Specifications subject to change without notice

Controls

Series 900 Universal Testing Machines have been designed with a simple yet accurate interface, making them useful for everything from quality control applications to high-end research. A diagram and detailed descriptions of the these controls can be found on this and the following page.

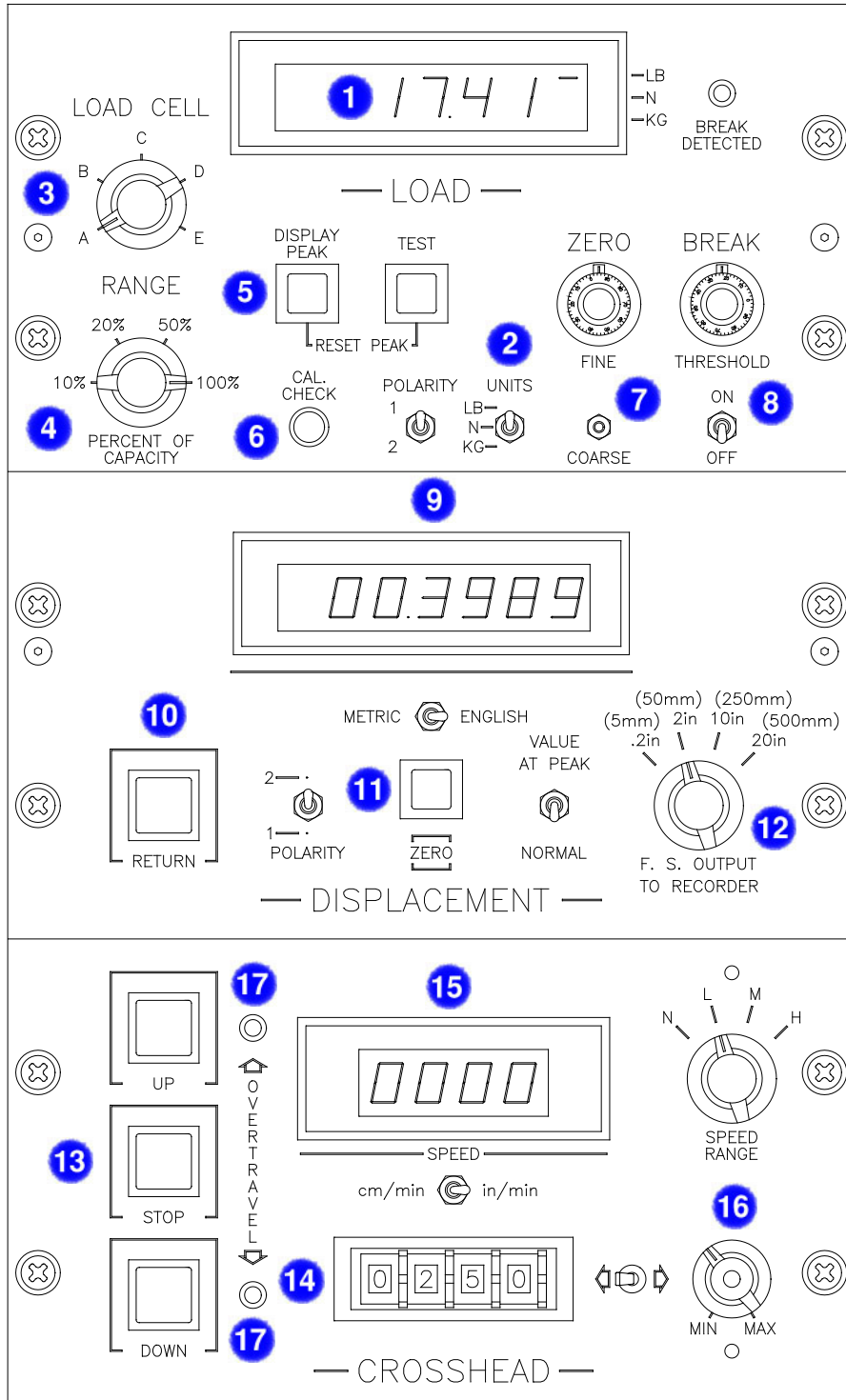

SERIES 900

LOAD

- 1 **Large digital readout display:** The precise load being applied to the specimen is clearly visible throughout the test. As an added safety feature, an **electronic overload protection system** automatically stops crosshead travel when 105% of the load range has been reached.
- 2 **Choice of measuring units:** Choose from pounds, Newtons, or kilograms at the flip of a switch. An illuminated LED at the far right of the display indicates which measuring unit is currently being used.
- 3 **Multiple load cell capacity:** Testing is not restricted to one load cell. Up to five different cells can be used, and auxiliary load cells can be added at any time.
- 4 **Selectable load cell range:** For increased accuracy, a range of 10%, 20%, 50%, or 100% of the capacity of the current load cell can be selected. Each range is independently calibrated and provides a full 0-10 VDC output to the recorder or data system.
- 5 **Peak load recall:** The maximum load achieved is automatically retained in memory, eliminating the need for monitoring the system during testing.
- 6 **Calibration verification:** A microprocessor-based signal conditioner is designed to maintain calibration, so daily calibration of the machine is not required. Calibration can be verified at any time by pressing the calibration check button.
- 7 **Fine and coarse zero adjustments:** The weights of pull rods, grips, and specimens (tare value) can be excluded from the test (up to 50% of the load cell capacity).
- 8 **Automatic break detection system:** Featuring adjustable sensitivity and an on/off control. When switched on, the break detector constantly monitors the current load and compares it to the peak load to determine whether a break has occurred.

DISPLACEMENT (Optional)

- 9 **Digital crosshead travel readout:** A high-resolution optical incremental encoder displays crosshead travel with resolution to 0.0001 in. Displacement can be displayed in inches or millimeters. When extensometers are not used, the output from the displacement measuring system can provide the signal for the x-axis on an x-y recorder.
- 10 **Rapid crosshead return:** The crosshead returns to zero or starting position at the push of a button, reducing setup time between tests.
- 11 **Zero reset button:** Reset the zero or starting position to the current position of the crosshead by pushing this button.
- 12 **Output range selector:** Provides units of 0.2 in., 2.0 in., 10 in., and 20 in. at 10V full scale.

CROSSHEAD

- 13 **Manual crosshead controls:** A set of “up-down-stop” buttons provide a simple interface for operating the machine.
- 14 **Precise speed selection:** Set the desired speed of the crosshead using this digital thumbwheel switch.
- 15 **Digital crosshead speed display:** Shows the actual speed of the crosshead, selectable in either inches or millimeters.
- 16 **Variable speed control:** Allows for test setup positioning without disturbing the preset test speed.
- 17 **Crosshead travel limit indicators:** These LEDs illuminate when limits have been reached in either direction. Mechanical user-adjustable limits are provided on the front of the machine to protect grips and fixtures from damage due to overtravel.

Custom Equipment

Applied Test Systems, Inc. has an excellent reputation in the materials testing industry as a leading supplier of custom equipment. We welcome all inquiries into any system or setup you may have in mind. Below are just a few examples of how we can put our decades of experience to work for you.



Series 910 UTM with extended vertical clearance. Integrated with cryogenic chamber.

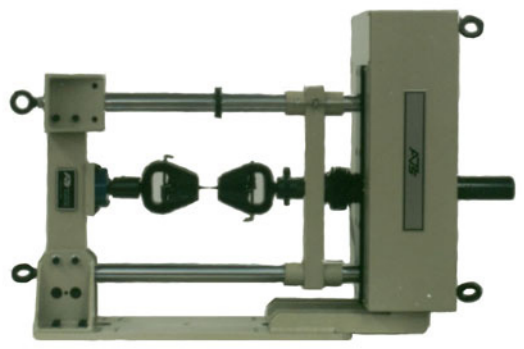

Series 910 UTM designed to be used for horizontal testing. Can also be mounted vertically to a wall or other support structure.



ACCREDITED
Calibration Laboratory
Certificate No. 2132.01
Inclusion of this logo does not imply certification/approval of the products calibrated.

ATS APPLIED TEST SYSTEMS, INC.
154 East Brook Lane
Butler, PA 16002
Phone: (724) 283-1212
Toll-Free: (800) 441-0215
Fax: (724) 283-6570
eMail: sales@atspa.com
<http://www.atspa.com>

CE Certification Program Now Available

